



# Rapid Tach Quick Couplers

## RT-III Series

### SPECIFICATIONS

| MODEL  | Coupler Weight      | (1) Excavator Class Size<br>(lbs.) (M Tons) |
|--------|---------------------|---|
| RT 40  | 700 Lbs. (318 Kg.)  | 35,000 – 47,000 Lbs. (16 – 21 M. Tons)      |
| RT 50  | 1000 Lbs. (454 Kg.) | 48,000 – 65,000 Lbs. (22 – 29 M. Tons)      |
| RT 70  | 1400 Lbs. (636 Kg.) | 66,000 – 85,000 Lbs. (30 – 38 M. Tons)      |
| RT 100 | 1800 Lbs. (818 Kg.) | 86,000 – 105,000 Lbs. (39 – 48 M. Tons)     |

(1) Excavator weight recommendation is based on standard excavator weights and boom and/or arm lengths. All applications must be approved by Stanley LaBounty prior to sale. Note: Weights, dimensions and operating specifications listed here are subject to change without notice. Where specifications are critical to your application, please consult Stanley.

**Stanley LaBounty® Rapid Tach-III Manual Couplers** are designed for contractors who want to fully utilize their excavators by being able to quickly change out a variety of attachments within minutes versus spending an hour or more removing pins. The Rapid Tach-III Coupler is the only pin grabbing coupler approved to handle Stanley LaBounty mechanical attachments such as CP Concrete Pulverizers, BLS Bucket Linkage Shears, MWS Wood Shears and HDR Grapples as well as Universal Processors.

#### Safety and Operational Features.

The patent pending, locking wedge assures a tight fit around the front pin. The tensioned, wedge-locking device provides added force to maintain a tight fit, reducing pin wear. A safety latch prevents the wedge from sliding out of the coupler should the locking device be removed unintentionally. The lifting eye on the front of the coupler can be used for lifting items but is also used as an added safety feature, which attaches a chain from the coupler to the attachment.

**Rapid Latch Mounting Pad.** The patent pending, Rapid Latch Mounting Pad is designed for easily attaching and removing mechanical attachments that utilize stiff arms such as those seen with LaBounty Grapples, Concrete Pulverizers, Bucket Linkage Shears and Wood Shears (please see reverse side for more information). When the stiff arm is engaged with the pad, the hook automatically rotates around the pin, allowing the locking wedge to be engaged.

### Rapid Tach-III Components

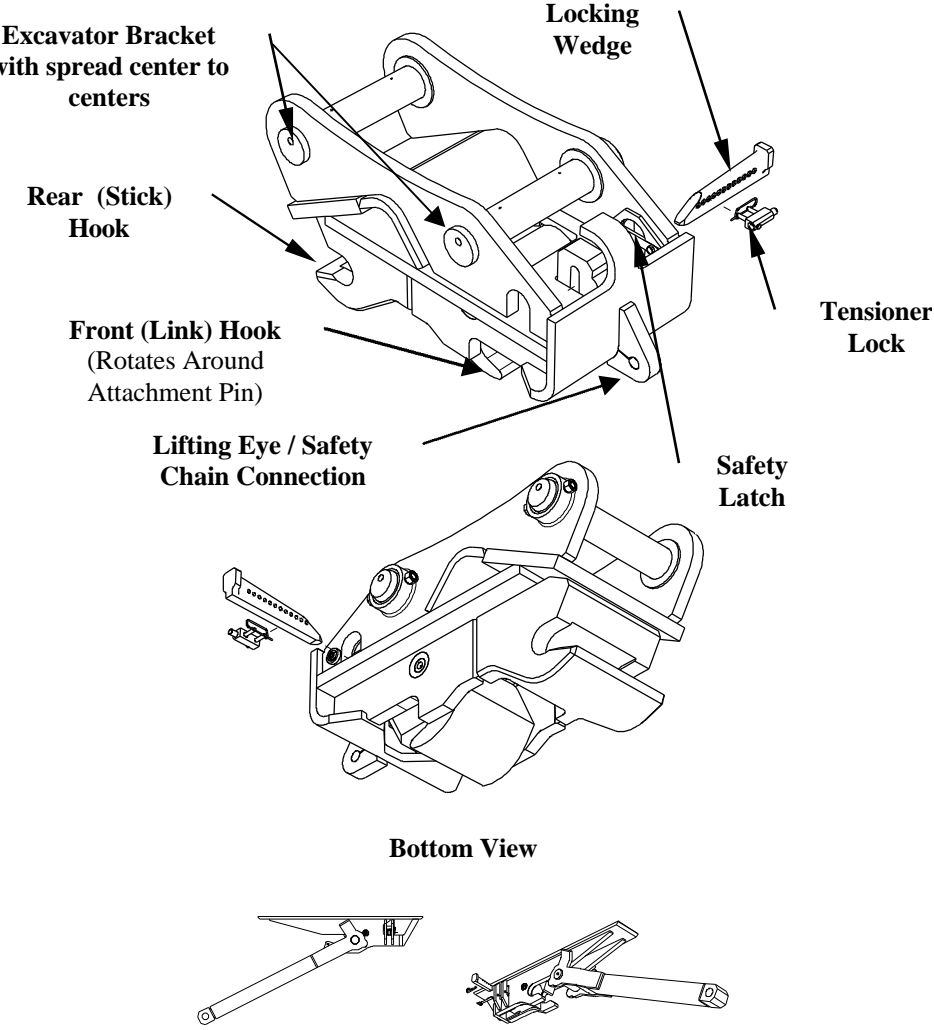

## ACCESSORIES / OPTIONS

- Additional Rapid Latch Mounting Pads and Stiff Arms Available

Attachments that can be used with the Rapid Tach-III Coupler Include:

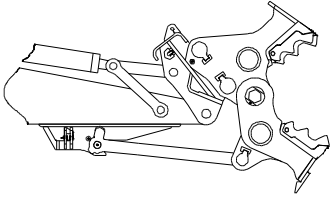

RT – III with LaBounty CP

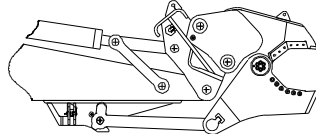

RT – III with LaBounty BLS  
Bucket Linkage Shear

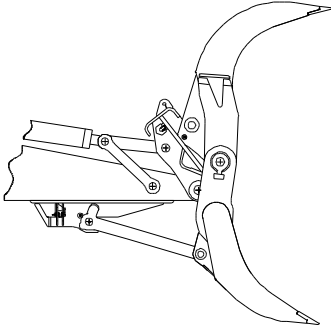

RT-III with LaBounty HDR  
Contractor's Grapple

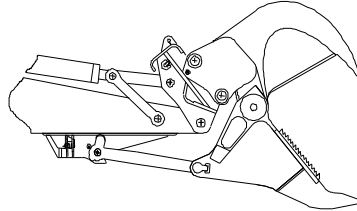

RT-III with LaBounty MWS  
Wood Shear

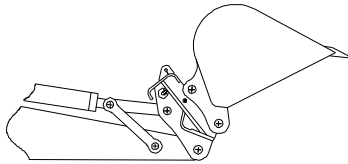

RT – III with Bucket

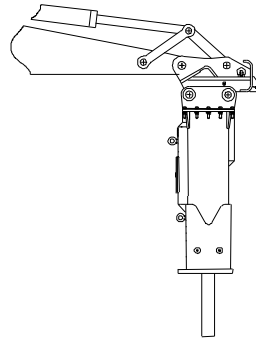

RT – III with Stanley  
Mounted Breaker

**Note:** Due to the spread centers on the excavator hook-up side, a loss of approximately 25% in spec opening can be expected. For buckets, a loss of up to 25° in curl can be expected.

The BLS, MWS, CP and HDR will double act, meaning the lower jaw will articulate during the cutting cycle. The illustrations below show how a CP will articulate when used in conjunction with the RT-III.

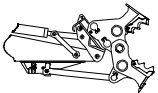

Fully Open

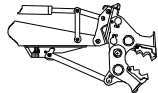

Partially Open

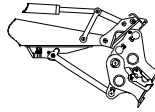

Closed

All Stanley LaBounty products are subject to design improvements, specification and price changes at any time without notice and with no obligation to units already sold. Weights, dimensions and operating specifications listed herein are subject to change without notice and may vary depending on mounting bracket options. Where specifications are critical to your application, please consult Stanley LaBounty.

## WARRANTY

All Rapid Tach – III Couplers are warranted against defects in materials and workmanship for a period of twelve months or 1500 hours from the date of purchase. Stanley LaBounty reserves the right to repair or replace only those parts, which prove to have been defective at the time of purchase. This warranty becomes void if maximum excavator flow and pressure ratings are exceeded. Please see the Stanley LaBounty warranty sheet, the Operations, Safety and Maintenance Manual or contact your LaBounty distributor for more information.

**Note:** Stanley LaBounty can offer you further flexibility by designing couplers to fit the different makes of excavators within the same weight class to grab one specific excavator's attachments. As an example, an RT 70 coupler could be designed to mount to a Cat® 330, yet the pin grabbing side could be designed to grab attachments designed for a Komatsu® PC 300.

**When ordering, please specify:**

- Excavator make, model and linkage package onto which the coupler will be pinned.
- Make, model and linkage family of the attachments the coupler will grab.

**Other Considerations:**

- Quick coupler surcharges are added to all BLS Shears, CP Concrete Pulverizers, MWS Wood Shears and HDR Grapples.
- All attachments that the coupler will handle must be designed to OEM bucket pin sizes and center to centers.
- One set of coupler pins is included in the price of the coupler.

**STANLEY**

*LaBounty*

**Stanley LaBounty**

1538 Highway 2  
Two Harbors, MN 55616 USA  
Tel: 218-834-2123 or 1-800-522-5059  
Fax: 218-834-3879